

Appendix 14.A – TRICS Output

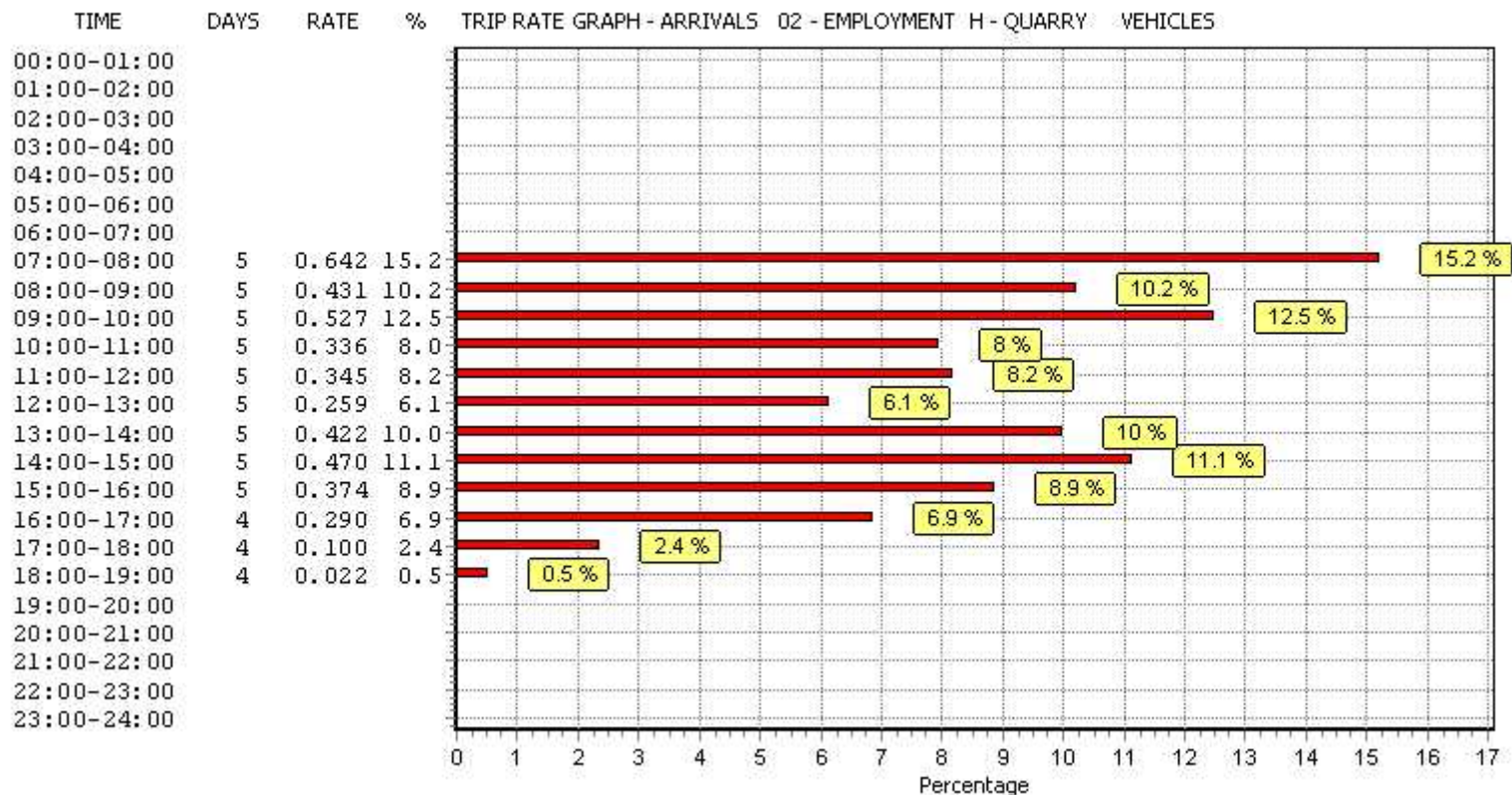

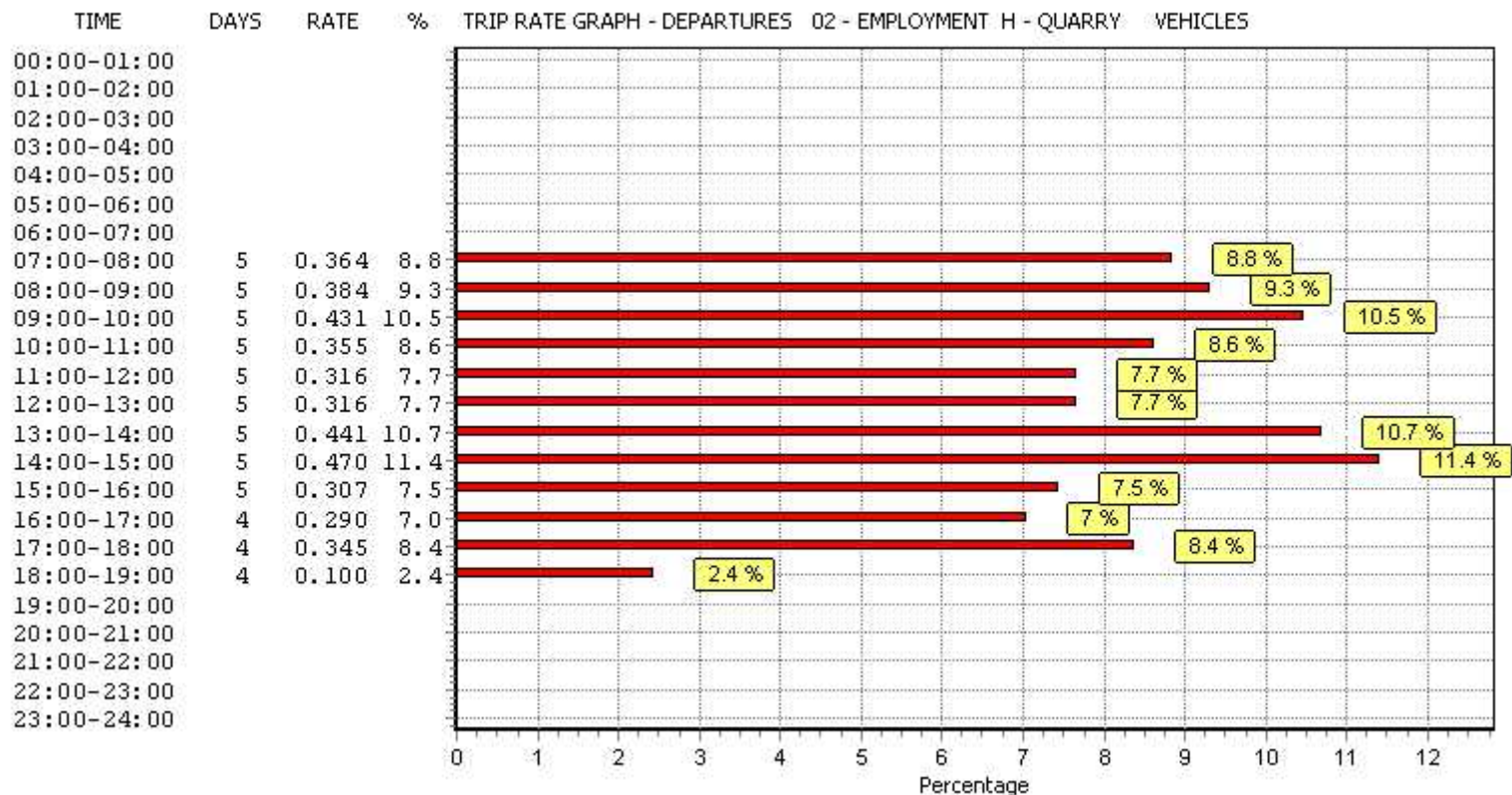

Appendix 14.B – Traffic Survey Data

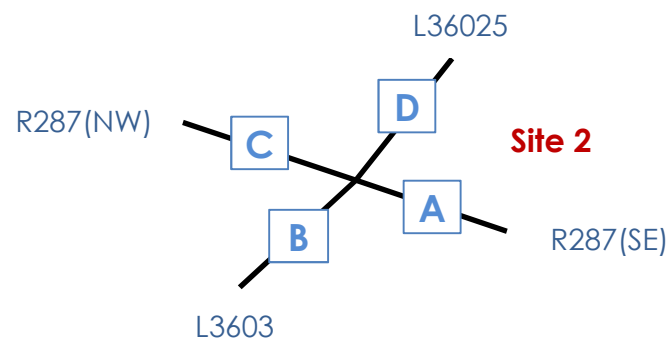
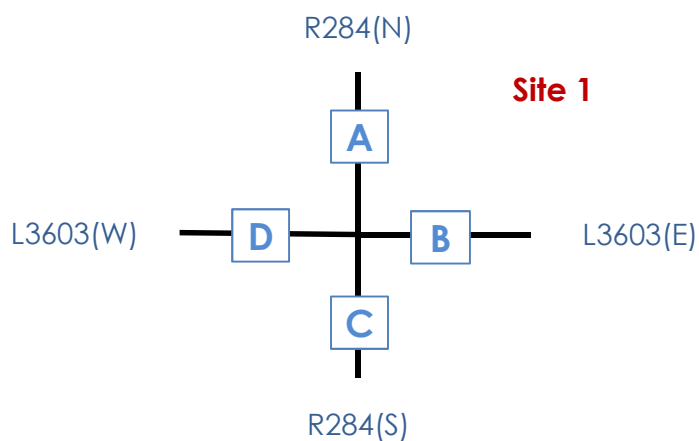
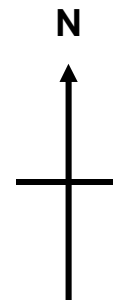

Sites / Location:	1 & 2 / Sligo	Project No:	8459	Drawing No:	8459-02	Drawn By:	AC		
	Survey Date:		Wednesday 21st February 2018		Project Name: AUGHNACLIFFE AND AUGHNAMORE				
	Survey Times:		07:00 to 19:00		Drawing Title: Site Layout and Observed Movements				

Site No. 1
Location R284(N) / L3603(E) / R284(S) / L3603(W)
Date 21 February 2018

Time	A to D - R284(N) to L3603(W)		Veh. Total	A to C - R284(N) to R284(S)		Veh. Total
	LV	HV		LV	HV	
07:00	0	0	0	1	1	2
07:15	0	0	0	3	1	4
07:30	0	0	0	5	0	5
07:45	2	0	2	6	0	6
Hour	2	0	2	15	2	17
08:00	2	0	2	6	0	6
08:15	1	0	1	12	0	12
08:30	1	0	1	21	0	21
08:45	6	0	6	17	3	20
Hour	10	0	10	56	3	59
09:00	3	0	3	16	2	18
09:15	0	0	0	8	1	9
09:30	2	0	2	12	0	12
09:45	2	0	2	7	1	8
Hour	7	0	7	43	4	47
10:00	2	0	2	13	2	15
10:15	0	0	0	7	1	8
10:30	0	0	0	15	1	16
10:45	1	1	2	9	1	10
Hour	3	1	4	44	5	49
11:00	0	0	0	18	0	18
11:15	0	0	0	17	1	18
11:30	2	0	2	15	1	16
11:45	1	0	1	14	1	15
Hour	3	0	3	64	3	67
12:00	1	0	1	13	2	15
12:15	2	0	2	14	1	15
12:30	2	0	2	19	2	21
12:45	0	0	0	15	0	15
Hour	5	0	5	61	5	66
13:00	3	0	3	17	0	17
13:15	2	0	2	22	0	22
13:30	1	0	1	15	0	15
13:45	3	0	3	15	1	16
Hour	9	0	9	69	1	70
14:00	2	0	2	16	1	17
14:15	1	0	1	21	0	21
14:30	5	0	5	26	1	27
14:45	3	0	3	11	1	12
Hour	11	0	11	74	3	77
15:00	0	0	0	26	2	28
15:15	1	0	1	23	1	24
15:30	3	0	3	24	1	25
15:45	0	0	0	22	0	22
Hour	4	0	4	95	4	99
16:00	3	0	3	24	0	24
16:15	2	0	2	34	1	35
16:30	3	0	3	39	0	39
16:45	1	0	1	33	1	34
Hour	9	0	9	130	2	132
17:00	4	0	4	42	2	44
17:15	2	0	2	39	1	40
17:30	0	0	0	49	0	49
17:45	3	0	3	45	0	45
Hour	9	0	9	175	3	178
18:00	2	0	2	44	0	44
18:15	3	0	3	46	1	47
18:30	2	0	2	21	0	21
18:45	1	0	1	23	1	24
Hour	8	0	8	134	2	136
Total	80	1	81	960	37	997

Site No. 1
Location R284(N) / L3603(E) / R284(S) / L3603(W)
Date 21 February 2018

Time	A to B - R284(N) to L3603(E)		Veh. Total	B to A - L3603(E) to R284(N)		Veh. Total
	LV	HV		LV	HV	
07:00	0	0	0	0	0	0
07:15	0	0	0	0	0	0
07:30	1	0	1	1	0	1
07:45	1	0	1	1	0	1
Hour	2	0	2	2	0	2
08:00	0	0	0	0	0	0
08:15	0	0	0	1	0	1
08:30	1	0	1	0	0	0
08:45	0	0	0	1	0	1
Hour	1	0	1	2	0	2
09:00	1	0	1	2	0	2
09:15	0	0	0	1	1	2
09:30	0	0	0	4	1	5
09:45	2	0	2	2	0	2
Hour	3	0	3	9	2	11
10:00	2	0	2	1	0	1
10:15	1	0	1	1	0	1
10:30	3	0	3	0	0	0
10:45	1	0	1	2	0	2
Hour	7	0	7	4	0	4
11:00	5	0	5	0	0	0
11:15	0	1	1	1	0	1
11:30	1	0	1	0	1	1
11:45	1	0	1	0	0	0
Hour	7	1	8	1	1	2
12:00	1	0	1	1	0	1
12:15	2	0	2	3	0	3
12:30	3	0	3	2	0	2
12:45	2	0	2	0	0	0
Hour	8	0	8	6	0	6
13:00	1	0	1	2	0	2
13:15	1	0	1	2	0	2
13:30	0	0	0	0	0	0
13:45	1	0	1	1	0	1
Hour	3	0	3	5	0	5
14:00	3	0	3	2	1	3
14:15	1	0	1	2	0	2
14:30	2	0	2	2	0	2
14:45	2	1	3	0	0	0
Hour	8	1	9	6	1	7
15:00	6	0	6	3	0	3
15:15	1	0	1	1	0	1
15:30	1	0	1	2	0	2
15:45	0	0	0	1	0	1
Hour	8	0	8	7	0	7
16:00	4	0	4	1	0	1
16:15	1	2	3	2	0	2
16:30	1	0	1	0	1	1
16:45	4	0	4	1	0	1
Hour	10	2	12	4	1	5
17:00	1	0	1	3	0	3
17:15	3	1	4	3	0	3
17:30	0	0	0	1	0	1
17:45	1	0	1	0	0	0
Hour	5	1	6	7	0	7
18:00	2	0	2	0	0	0
18:15	2	0	2	0	0	0
18:30	2	0	2	0	0	0
18:45	0	0	0	2	0	2
Hour	6	0	6	2	0	2
Total	68	5	73	55	5	60

Site No. 1
Location R284(N) / L3603(E) / R284(S) / L3603(W)
Date 21 February 2018

Time	B to D - L3603(E) to L3603(W)		Veh. Total	B to C - L3603(E) to R284(S)		Veh. Total
	LV	HV		LV	HV	
07:00	0	0	0	0	0	0
07:15	0	0	0	0	0	0
07:30	2	0	2	0	0	0
07:45	3	0	3	0	0	0
Hour	5	0	5	0	0	0
08:00	2	2	4	1	0	1
08:15	3	0	3	0	0	0
08:30	3	2	5	0	0	0
08:45	4	0	4	0	0	0
Hour	12	4	16	1	0	1
09:00	1	0	1	0	0	0
09:15	0	1	1	0	0	0
09:30	2	0	2	0	0	0
09:45	1	0	1	2	0	2
Hour	4	1	5	2	0	2
10:00	2	1	3	3	0	3
10:15	1	0	1	0	0	0
10:30	0	0	0	0	0	0
10:45	3	0	3	1	0	1
Hour	6	1	7	4	0	4
11:00	1	0	1	0	0	0
11:15	0	0	0	1	0	1
11:30	3	0	3	2	0	2
11:45	1	0	1	0	0	0
Hour	5	0	5	3	0	3
12:00	4	2	6	0	0	0
12:15	1	0	1	1	0	1
12:30	3	0	3	1	0	1
12:45	0	0	0	0	0	0
Hour	8	2	10	2	0	2
13:00	2	0	2	0	0	0
13:15	1	0	1	2	0	2
13:30	6	0	6	1	0	1
13:45	1	0	1	0	0	0
Hour	10	0	10	3	0	3
14:00	1	1	2	1	0	1
14:15	0	0	0	2	0	2
14:30	0	0	0	1	0	1
14:45	0	0	0	0	0	0
Hour	1	1	2	4	0	4
15:00	0	1	1	1	0	1
15:15	0	0	0	0	0	0
15:30	2	0	2	1	0	1
15:45	4	0	4	3	0	3
Hour	6	1	7	5	0	5
16:00	2	1	3	3	0	3
16:15	3	1	4	2	0	2
16:30	3	1	4	2	0	2
16:45	2	0	2	1	0	1
Hour	10	3	13	8	0	8
17:00	3	0	3	3	0	3
17:15	4	0	4	2	0	2
17:30	4	0	4	2	0	2
17:45	3	0	3	2	0	2
Hour	14	0	14	9	0	9
18:00	1	0	1	1	0	1
18:15	1	0	1	1	0	1
18:30	2	1	3	1	0	1
18:45	1	0	1	0	0	0
Hour	5	1	6	3	0	3
Total	86	14	100	44	0	44

Site No. 1
Location R284(N) / L3603(E) / R284(S) / L3603(W)
Date 21 February 2018

Time	C to B - R284(S) to L3603(E)		Veh. Total	C to A - R284(S) to R284(N)		Veh. Total
	LV	HV		LV	HV	
07:00	0	0	0	7	2	9
07:15	1	0	1	14	0	14
07:30	0	0	0	34	0	34
07:45	1	0	1	40	3	43
Hour	2	0	2	95	5	100
08:00	1	0	1	45	0	45
08:15	2	0	2	63	0	63
08:30	6	0	6	51	1	52
08:45	4	0	4	37	2	39
Hour	13	0	13	196	3	199
09:00	2	1	3	33	1	34
09:15	1	0	1	36	0	36
09:30	0	0	0	31	1	32
09:45	1	0	1	19	0	19
Hour	4	1	5	119	2	121
10:00	0	0	0	16	0	16
10:15	0	0	0	24	1	25
10:30	1	0	1	27	1	28
10:45	0	0	0	22	1	23
Hour	1	0	1	89	3	92
11:00	1	0	1	22	0	22
11:15	0	0	0	12	1	13
11:30	0	0	0	24	1	25
11:45	0	0	0	30	0	30
Hour	1	0	1	88	2	90
12:00	0	0	0	17	0	17
12:15	0	0	0	18	0	18
12:30	1	0	1	18	1	19
12:45	0	0	0	14	0	14
Hour	1	0	1	67	1	68
13:00	2	1	3	10	0	10
13:15	0	0	0	17	1	18
13:30	1	0	1	19	1	20
13:45	0	0	0	18	0	18
Hour	3	1	4	64	2	66
14:00	0	0	0	17	2	19
14:15	0	0	0	12	1	13
14:30	2	0	2	22	2	24
14:45	0	0	0	17	0	17
Hour	2	0	2	68	5	73
15:00	0	0	0	20	0	20
15:15	0	0	0	23	0	23
15:30	1	0	1	18	0	18
15:45	1	0	1	18	4	22
Hour	2	0	2	79	4	83
16:00	0	0	0	26	4	30
16:15	0	0	0	16	1	17
16:30	0	0	0	21	0	21
16:45	0	0	0	15	0	15
Hour	0	0	0	78	5	83
17:00	1	0	1	23	0	23
17:15	2	0	2	19	1	20
17:30	1	0	1	23	1	24
17:45	0	0	0	22	0	22
Hour	4	0	4	87	2	89
18:00	0	0	0	19	0	19
18:15	0	0	0	12	0	12
18:30	1	0	1	17	0	17
18:45	0	0	0	16	1	17
Hour	1	0	1	64	1	65
Total	34	2	36	1094	35	1129

Site No. 1
Location R284(N) / L3603(E) / R284(S) / L3603(W)
Date 21 February 2018

Time	C to D - R284(S) to L3603(W)		Veh. Total	D to C - L3603(W) to R284(S)		Veh. Total
	LV	HV		LV	HV	
07:00	1	0	1	0	0	0
07:15	0	0	0	0	0	0
07:30	1	0	1	0	0	0
07:45	0	0	0	1	0	1
Hour	2	0	2	1	0	1
08:00	0	0	0	0	0	0
08:15	6	0	6	1	0	1
08:30	12	0	12	1	0	1
08:45	16	1	17	2	0	2
Hour	34	1	35	4	0	4
09:00	3	0	3	1	0	1
09:15	1	0	1	4	0	4
09:30	5	0	5	0	0	0
09:45	1	0	1	1	0	1
Hour	10	0	10	6	0	6
10:00	1	0	1	0	1	1
10:15	2	0	2	1	0	1
10:30	1	0	1	0	1	1
10:45	0	0	0	2	0	2
Hour	4	0	4	3	2	5
11:00	2	1	3	2	0	2
11:15	0	0	0	1	0	1
11:30	2	0	2	1	0	1
11:45	1	1	2	2	0	2
Hour	5	2	7	6	0	6
12:00	0	0	0	1	0	1
12:15	0	0	0	0	1	1
12:30	0	0	0	2	0	2
12:45	3	0	3	1	0	1
Hour	3	0	3	4	1	5
13:00	2	0	2	2	0	2
13:15	0	1	1	1	0	1
13:30	3	0	3	1	0	1
13:45	4	1	5	0	0	0
Hour	9	2	11	4	0	4
14:00	1	0	1	0	0	0
14:15	2	0	2	3	0	3
14:30	2	0	2	3	1	4
14:45	1	0	1	0	0	0
Hour	6	0	6	6	1	7
15:00	0	0	0	2	0	2
15:15	1	0	1	0	0	0
15:30	2	0	2	3	0	3
15:45	2	1	3	0	1	1
Hour	5	1	6	5	1	6
16:00	2	2	4	3	0	3
16:15	5	0	5	2	0	2
16:30	1	0	1	3	0	3
16:45	1	0	1	0	0	0
Hour	9	2	11	8	0	8
17:00	2	0	2	1	0	1
17:15	1	0	1	4	0	4
17:30	0	0	0	3	0	3
17:45	2	0	2	2	0	2
Hour	5	0	5	10	0	10
18:00	0	1	1	3	0	3
18:15	1	0	1	2	0	2
18:30	0	0	0	2	0	2
18:45	2	0	2	1	0	1
Hour	3	1	4	8	0	8
Total	95	9	104	65	5	70

Site No. 1
Location R284(N) / L3603(E) / R284(S) / L3603(W)
Date 21 February 2018

Time	D to B - L3603(W) to L3603(E)		Veh. Total	D to A - L3603(W) to R284(N)		Veh. Total
	LV	HV		LV	HV	
07:00	0	0	0	2	0	2
07:15	0	0	0	0	0	0
07:30	5	0	5	3	0	3
07:45	1	0	1	0	0	0
Hour	6	0	6	5	0	5
08:00	0	0	0	0	0	0
08:15	0	0	0	1	0	1
08:30	0	0	0	0	0	0
08:45	3	1	4	1	0	1
Hour	3	1	4	2	0	2
09:00	3	0	3	1	0	1
09:15	1	0	1	1	0	1
09:30	1	1	2	1	0	1
09:45	3	0	3	2	0	2
Hour	8	1	9	5	0	5
10:00	0	0	0	1	0	1
10:15	2	0	2	2	0	2
10:30	0	0	0	1	0	1
10:45	1	0	1	1	0	1
Hour	3	0	3	5	0	5
11:00	2	0	2	3	0	3
11:15	1	0	1	0	0	0
11:30	3	0	3	1	0	1
11:45	1	0	1	1	0	1
Hour	7	0	7	5	0	5
12:00	1	2	3	0	0	0
12:15	0	0	0	1	0	1
12:30	2	0	2	1	0	1
12:45	1	0	1	0	0	0
Hour	4	2	6	2	0	2
13:00	2	0	2	3	0	3
13:15	0	0	0	3	0	3
13:30	0	0	0	1	0	1
13:45	0	0	0	0	0	0
Hour	2	0	2	7	0	7
14:00	3	0	3	0	0	0
14:15	2	0	2	1	0	1
14:30	0	0	0	3	0	3
14:45	1	1	2	0	0	0
Hour	6	1	7	4	0	4
15:00	0	0	0	0	0	0
15:15	3	1	4	0	0	0
15:30	1	0	1	1	0	1
15:45	2	0	2	0	0	0
Hour	6	1	7	1	0	1
16:00	0	0	0	3	0	3
16:15	2	0	2	5	0	5
16:30	0	0	0	2	0	2
16:45	2	0	2	0	0	0
Hour	4	0	4	10	0	10
17:00	2	0	2	2	0	2
17:15	1	0	1	2	0	2
17:30	4	0	4	2	0	2
17:45	1	0	1	3	0	3
Hour	8	0	8	9	0	9
18:00	2	0	2	2	0	2
18:15	1	0	1	1	0	1
18:30	1	0	1	1	0	1
18:45	0	0	0	3	0	3
Hour	4	0	4	7	0	7
Total	61	6	67	62	0	62

Site No. 1
Location R284(N) / L3603(E) / R284(S) / L3603(W)
Date 21 February 2018

Time	To Arm A - R284(N)		Veh. Total	From Arm A - R284(N)		Veh. Total
	LV	HV		LV	HV	
07:00	9	2	11	1	1	2
07:15	14	0	14	3	1	4
07:30	38	0	38	6	0	6
07:45	41	3	44	9	0	9
Hour	102	5	107	19	2	21
08:00	45	0	45	8	0	8
08:15	65	0	65	13	0	13
08:30	51	1	52	23	0	23
08:45	39	2	41	23	3	26
Hour	200	3	203	67	3	70
09:00	36	1	37	20	2	22
09:15	38	1	39	8	1	9
09:30	36	2	38	14	0	14
09:45	23	0	23	11	1	12
Hour	133	4	137	53	4	57
10:00	18	0	18	17	2	19
10:15	27	1	28	8	1	9
10:30	28	1	29	18	1	19
10:45	25	1	26	11	2	13
Hour	98	3	101	54	6	60
11:00	25	0	25	23	0	23
11:15	13	1	14	17	2	19
11:30	25	2	27	18	1	19
11:45	31	0	31	16	1	17
Hour	94	3	97	74	4	78
12:00	18	0	18	15	2	17
12:15	22	0	22	18	1	19
12:30	21	1	22	24	2	26
12:45	14	0	14	17	0	17
Hour	75	1	76	74	5	79
13:00	15	0	15	21	0	21
13:15	22	1	23	25	0	25
13:30	20	1	21	16	0	16
13:45	19	0	19	19	1	20
Hour	76	2	78	81	1	82
14:00	19	3	22	21	1	22
14:15	15	1	16	23	0	23
14:30	27	2	29	33	1	34
14:45	17	0	17	16	2	18
Hour	78	6	84	93	4	97
15:00	23	0	23	32	2	34
15:15	24	0	24	25	1	26
15:30	21	0	21	28	1	29
15:45	19	4	23	22	0	22
Hour	87	4	91	107	4	111
16:00	30	4	34	31	0	31
16:15	23	1	24	37	3	40
16:30	23	1	24	43	0	43
16:45	16	0	16	38	1	39
Hour	92	6	98	149	4	153
17:00	28	0	28	47	2	49
17:15	24	1	25	44	2	46
17:30	26	1	27	49	0	49
17:45	25	0	25	49	0	49
Hour	103	2	105	189	4	193
18:00	21	0	21	48	0	48
18:15	13	0	13	51	1	52
18:30	18	0	18	25	0	25
18:45	21	1	22	24	1	25
Hour	73	1	74	148	2	150
Total	1211	40	1251	1108	43	1151

Site No. 1
Location R284(N) / L3603(E) / R284(S) / L3603(W)
Date 21 February 2018

Time	To Arm B - L3603(E)		Veh. Total	From Arm B - L3603(E)		Veh. Total
	LV	HV		LV	HV	
07:00	0	0	0	0	0	0
07:15	1	0	1	0	0	0
07:30	6	0	6	3	0	3
07:45	3	0	3	4	0	4
Hour	10	0	10	7	0	7
08:00	1	0	1	3	2	5
08:15	2	0	2	4	0	4
08:30	7	0	7	3	2	5
08:45	7	1	8	5	0	5
Hour	17	1	18	15	4	19
09:00	6	1	7	3	0	3
09:15	2	0	2	1	2	3
09:30	1	1	2	6	1	7
09:45	6	0	6	5	0	5
Hour	15	2	17	15	3	18
10:00	2	0	2	6	1	7
10:15	3	0	3	2	0	2
10:30	4	0	4	0	0	0
10:45	2	0	2	6	0	6
Hour	11	0	11	14	1	15
11:00	8	0	8	1	0	1
11:15	1	1	2	2	0	2
11:30	4	0	4	5	1	6
11:45	2	0	2	1	0	1
Hour	15	1	16	9	1	10
12:00	2	2	4	5	2	7
12:15	2	0	2	5	0	5
12:30	6	0	6	6	0	6
12:45	3	0	3	0	0	0
Hour	13	2	15	16	2	18
13:00	5	1	6	4	0	4
13:15	1	0	1	5	0	5
13:30	1	0	1	7	0	7
13:45	1	0	1	2	0	2
Hour	8	1	9	18	0	18
14:00	6	0	6	4	2	6
14:15	3	0	3	4	0	4
14:30	4	0	4	3	0	3
14:45	3	2	5	0	0	0
Hour	16	2	18	11	2	13
15:00	6	0	6	4	1	5
15:15	4	1	5	1	0	1
15:30	3	0	3	5	0	5
15:45	3	0	3	8	0	8
Hour	16	1	17	18	1	19
16:00	4	0	4	6	1	7
16:15	3	2	5	7	1	8
16:30	1	0	1	5	2	7
16:45	6	0	6	4	0	4
Hour	14	2	16	22	4	26
17:00	4	0	4	9	0	9
17:15	6	1	7	9	0	9
17:30	5	0	5	7	0	7
17:45	2	0	2	5	0	5
Hour	17	1	18	30	0	30
18:00	4	0	4	2	0	2
18:15	3	0	3	2	0	2
18:30	4	0	4	3	1	4
18:45	0	0	0	3	0	3
Hour	11	0	11	10	1	11
Total	163	13	176	185	19	204

Site No. 1
Location R284(N) / L3603(E) / R284(S) / L3603(W)
Date 21 February 2018

Time	To Arm C - R284(S)		Veh. Total	From Arm C - R284(S)		Veh. Total
	LV	HV		LV	HV	
07:00	1	1	2	8	2	10
07:15	3	1	4	15	0	15
07:30	5	0	5	35	0	35
07:45	7	0	7	41	3	44
Hour	16	2	18	99	5	104
08:00	7	0	7	46	0	46
08:15	13	0	13	71	0	71
08:30	22	0	22	69	1	70
08:45	19	3	22	57	3	60
Hour	61	3	64	243	4	247
09:00	17	2	19	38	2	40
09:15	12	1	13	38	0	38
09:30	12	0	12	36	1	37
09:45	10	1	11	21	0	21
Hour	51	4	55	133	3	136
10:00	16	3	19	17	0	17
10:15	8	1	9	26	1	27
10:30	15	2	17	29	1	30
10:45	12	1	13	22	1	23
Hour	51	7	58	94	3	97
11:00	20	0	20	25	1	26
11:15	19	1	20	12	1	13
11:30	18	1	19	26	1	27
11:45	16	1	17	31	1	32
Hour	73	3	76	94	4	98
12:00	14	2	16	17	0	17
12:15	15	2	17	18	0	18
12:30	22	2	24	19	1	20
12:45	16	0	16	17	0	17
Hour	67	6	73	71	1	72
13:00	19	0	19	14	1	15
13:15	25	0	25	17	2	19
13:30	17	0	17	23	1	24
13:45	15	1	16	22	1	23
Hour	76	1	77	76	5	81
14:00	17	1	18	18	2	20
14:15	26	0	26	14	1	15
14:30	30	2	32	26	2	28
14:45	11	1	12	18	0	18
Hour	84	4	88	76	5	81
15:00	29	2	31	20	0	20
15:15	23	1	24	24	0	24
15:30	28	1	29	21	0	21
15:45	25	1	26	21	5	26
Hour	105	5	110	86	5	91
16:00	30	0	30	28	6	34
16:15	38	1	39	21	1	22
16:30	44	0	44	22	0	22
16:45	34	1	35	16	0	16
Hour	146	2	148	87	7	94
17:00	46	2	48	26	0	26
17:15	45	1	46	22	1	23
17:30	54	0	54	24	1	25
17:45	49	0	49	24	0	24
Hour	194	3	197	96	2	98
18:00	48	0	48	19	1	20
18:15	49	1	50	13	0	13
18:30	24	0	24	18	0	18
18:45	24	1	25	18	1	19
Hour	145	2	147	68	2	70
Total	1069	42	1111	1223	46	1269

Site No. 1
Location R284(N) / L3603(E) / R284(S) / L3603(W)
Date 21 February 2018

Time	To Arm D - L3603(W)		Veh. Total	From Arm D - L3603(W)		Veh. Total
	LV	HV		LV	HV	
07:00	1	0	1	2	0	2
07:15	0	0	0	0	0	0
07:30	3	0	3	8	0	8
07:45	5	0	5	2	0	2
Hour	9	0	9	12	0	12
08:00	4	2	6	0	0	0
08:15	10	0	10	2	0	2
08:30	16	2	18	1	0	1
08:45	26	1	27	6	1	7
Hour	56	5	61	9	1	10
09:00	7	0	7	5	0	5
09:15	1	1	2	6	0	6
09:30	9	0	9	2	1	3
09:45	4	0	4	6	0	6
Hour	21	1	22	19	1	20
10:00	5	1	6	1	1	2
10:15	3	0	3	5	0	5
10:30	1	0	1	1	1	2
10:45	4	1	5	4	0	4
Hour	13	2	15	11	2	13
11:00	3	1	4	7	0	7
11:15	0	0	0	2	0	2
11:30	7	0	7	5	0	5
11:45	3	1	4	4	0	4
Hour	13	2	15	18	0	18
12:00	5	2	7	2	2	4
12:15	3	0	3	1	1	2
12:30	5	0	5	5	0	5
12:45	3	0	3	2	0	2
Hour	16	2	18	10	3	13
13:00	7	0	7	7	0	7
13:15	3	1	4	4	0	4
13:30	10	0	10	2	0	2
13:45	8	1	9	0	0	0
Hour	28	2	30	13	0	13
14:00	4	1	5	3	0	3
14:15	3	0	3	6	0	6
14:30	7	0	7	6	1	7
14:45	4	0	4	1	1	2
Hour	18	1	19	16	2	18
15:00	0	1	1	2	0	2
15:15	2	0	2	3	1	4
15:30	7	0	7	5	0	5
15:45	6	1	7	2	1	3
Hour	15	2	17	12	2	14
16:00	7	3	10	6	0	6
16:15	10	1	11	9	0	9
16:30	7	1	8	5	0	5
16:45	4	0	4	2	0	2
Hour	28	5	33	22	0	22
17:00	9	0	9	5	0	5
17:15	7	0	7	7	0	7
17:30	4	0	4	9	0	9
17:45	8	0	8	6	0	6
Hour	28	0	28	27	0	27
18:00	3	1	4	7	0	7
18:15	5	0	5	4	0	4
18:30	4	1	5	4	0	4
18:45	4	0	4	4	0	4
Hour	16	2	18	19	0	19
Total	261	24	285	188	11	199

Site No. 2
Location R287(SE) / L3603 / R287(NW) / L36025
Date 21 February 2018

Time	A to D - R287(SE) to L36025		Veh. Total	A to C - R287(SE) to R287(NW)		Veh. Total
	LV	HV		LV	HV	
07:00	0	0	0	4	0	4
07:15	0	0	0	8	0	8
07:30	0	0	0	21	0	21
07:45	2	0	2	43	0	43
Hour	2	0	2	76	0	76
08:00	2	0	2	30	1	31
08:15	8	0	8	42	0	42
08:30	5	0	5	34	0	34
08:45	8	0	8	22	0	22
Hour	23	0	23	128	1	129
09:00	7	0	7	24	0	24
09:15	2	0	2	25	0	25
09:30	5	0	5	23	1	24
09:45	3	0	3	25	0	25
Hour	17	0	17	97	1	98
10:00	2	0	2	13	0	13
10:15	1	0	1	17	0	17
10:30	1	0	1	10	1	11
10:45	2	0	2	15	1	16
Hour	6	0	6	55	2	57
11:00	0	0	0	8	0	8
11:15	2	0	2	9	0	9
11:30	2	0	2	8	0	8
11:45	2	0	2	11	2	13
Hour	6	0	6	36	2	38
12:00	2	0	2	17	0	17
12:15	0	0	0	14	0	14
12:30	2	0	2	10	0	10
12:45	1	0	1	9	1	10
Hour	5	0	5	50	1	51
13:00	1	0	1	11	1	12
13:15	2	0	2	17	1	18
13:30	1	0	1	13	0	13
13:45	4	0	4	11	0	11
Hour	8	0	8	52	2	54
14:00	1	0	1	10	0	10
14:15	1	0	1	17	0	17
14:30	1	0	1	12	1	13
14:45	0	0	0	16	0	16
Hour	3	0	3	55	1	56
15:00	4	0	4	13	0	13
15:15	2	0	2	17	2	19
15:30	0	0	0	20	0	20
15:45	0	0	0	11	0	11
Hour	6	0	6	61	2	63
16:00	3	0	3	13	1	14
16:15	1	0	1	13	2	15
16:30	2	0	2	10	0	10
16:45	2	0	2	15	0	15
Hour	8	0	8	51	3	54
17:00	2	0	2	15	0	15
17:15	4	0	4	10	1	11
17:30	3	0	3	16	1	17
17:45	1	0	1	13	0	13
Hour	10	0	10	54	2	56
18:00	0	0	0	11	0	11
18:15	3	0	3	18	0	18
18:30	2	0	2	8	0	8
18:45	0	0	0	9	0	9
Hour	5	0	5	46	0	46
Total	99	0	99	761	17	778

Site No. 2
Location R287(SE) / L3603 / R287(NW) / L36025
Date 21 February 2018

Time	A to B - R287(SE) to L3603		Veh. Total	B to A - L3603 to R287(SE)		Veh. Total
	LV	HV		LV	HV	
07:00	0	0	0	0	0	0
07:15	0	0	0	0	0	0
07:30	1	0	1	2	0	2
07:45	4	1	5	2	0	2
Hour	5	1	6	4	0	4
08:00	0	0	0	0	0	0
08:15	0	0	0	0	0	0
08:30	3	0	3	0	0	0
08:45	3	0	3	2	0	2
Hour	6	0	6	2	0	2
09:00	0	0	0	1	0	1
09:15	0	1	1	1	0	1
09:30	1	0	1	2	0	2
09:45	1	0	1	4	0	4
Hour	2	1	3	8	0	8
10:00	3	0	3	1	0	1
10:15	1	0	1	0	0	0
10:30	1	0	1	1	0	1
10:45	2	0	2	2	0	2
Hour	7	0	7	4	0	4
11:00	0	0	0	1	0	1
11:15	0	0	0	1	0	1
11:30	1	0	1	0	0	0
11:45	1	0	1	2	0	2
Hour	2	0	2	4	0	4
12:00	3	0	3	3	2	5
12:15	1	0	1	1	0	1
12:30	0	0	0	1	0	1
12:45	0	0	0	0	0	0
Hour	4	0	4	5	2	7
13:00	2	0	2	0	0	0
13:15	0	0	0	1	0	1
13:30	2	0	2	0	0	0
13:45	0	0	0	0	0	0
Hour	4	0	4	1	0	1
14:00	1	0	1	0	0	0
14:15	1	0	1	1	0	1
14:30	0	0	0	1	0	1
14:45	1	0	1	1	0	1
Hour	3	0	3	3	0	3
15:00	0	0	0	0	0	0
15:15	1	0	1	0	0	0
15:30	3	1	4	1	0	1
15:45	2	0	2	2	0	2
Hour	6	1	7	3	0	3
16:00	2	1	3	0	0	0
16:15	2	1	3	1	0	1
16:30	1	0	1	0	0	0
16:45	1	0	1	1	0	1
Hour	6	2	8	2	0	2
17:00	2	0	2	1	0	1
17:15	0	0	0	1	0	1
17:30	1	0	1	0	0	0
17:45	0	0	0	2	0	2
Hour	3	0	3	4	0	4
18:00	0	0	0	1	0	1
18:15	0	0	0	0	0	0
18:30	1	0	1	1	0	1
18:45	0	0	0	2	0	2
Hour	1	0	1	4	0	4
Total	49	5	54	44	2	46

Site No. 2
Location R287(SE) / L3603 / R287(NW) / L36025
Date 21 February 2018

Time	B to D - L3603 to L36025		Veh. Total	B to C - L3603 to R287(NW)		Veh. Total
	LV	HV		LV	HV	
07:00	0	0	0	0	0	0
07:15	0	0	0	1	0	1
07:30	0	0	0	0	0	0
07:45	0	0	0	0	1	1
Hour	0	0	0	1	1	2
08:00	2	0	2	5	0	5
08:15	0	0	0	0	0	0
08:30	2	0	2	1	1	2
08:45	6	0	6	0	0	0
Hour	10	0	10	6	1	7
09:00	2	0	2	0	0	0
09:15	0	0	0	2	0	2
09:30	0	0	0	0	0	0
09:45	1	0	1	0	1	1
Hour	3	0	3	2	1	3
10:00	0	0	0	0	0	0
10:15	1	0	1	0	0	0
10:30	0	0	0	1	0	1
10:45	0	0	0	1	0	1
Hour	1	0	1	2	0	2
11:00	1	0	1	1	0	1
11:15	1	0	1	0	0	0
11:30	2	0	2	1	1	2
11:45	0	0	0	0	0	0
Hour	4	0	4	2	1	3
12:00	0	0	0	0	0	0
12:15	0	0	0	0	0	0
12:30	0	0	0	0	0	0
12:45	1	0	1	1	0	1
Hour	1	0	1	1	0	1
13:00	1	0	1	3	1	4
13:15	1	0	1	0	0	0
13:30	0	0	0	0	1	1
13:45	0	0	0	0	0	0
Hour	2	0	2	3	2	5
14:00	0	0	0	1	1	2
14:15	1	0	1	2	0	2
14:30	0	0	0	0	1	1
14:45	2	0	2	0	0	0
Hour	3	0	3	3	2	5
15:00	0	0	0	2	1	3
15:15	0	0	0	1	0	1
15:30	2	0	2	0	0	0
15:45	1	0	1	0	0	0
Hour	3	0	3	3	1	4
16:00	0	0	0	0	0	0
16:15	0	0	0	0	0	0
16:30	0	0	0	0	0	0
16:45	1	0	1	0	0	0
Hour	1	0	1	0	0	0
17:00	0	0	0	1	0	1
17:15	0	0	0	0	2	2
17:30	1	0	1	3	0	3
17:45	0	0	0	0	0	0
Hour	1	0	1	4	2	6
18:00	0	0	0	0	0	0
18:15	0	0	0	0	0	0
18:30	1	0	1	0	0	0
18:45	0	0	0	0	0	0
Hour	1	0	1	0	0	0
Total	30	0	30	27	11	38

Site No. 2
Location R287(SE) / L3603 / R287(NW) / L36025
Date 21 February 2018

Time	C to B - R287(NW) to L3603		Veh. Total	C to A - R287(NW) to R287(SE)		Veh. Total
	LV	HV		LV	HV	
07:00	0	0	0	1	0	1
07:15	0	0	0	3	1	4
07:30	0	0	0	1	1	2
07:45	1	0	1	8	0	8
Hour	1	0	1	13	2	15
08:00	2	1	3	5	0	5
08:15	1	1	2	13	0	13
08:30	0	1	1	12	1	13
08:45	0	0	0	12	0	12
Hour	3	3	6	42	1	43
09:00	0	0	0	19	0	19
09:15	2	0	2	9	0	9
09:30	1	0	1	8	1	9
09:45	1	1	2	13	0	13
Hour	4	1	5	49	1	50
10:00	0	0	0	14	0	14
10:15	1	0	1	12	1	13
10:30	0	1	1	10	0	10
10:45	0	0	0	11	0	11
Hour	1	1	2	47	1	48
11:00	0	0	0	9	1	10
11:15	1	2	3	16	2	18
11:30	2	0	2	11	0	11
11:45	2	0	2	17	0	17
Hour	5	2	7	53	3	56
12:00	1	0	1	10	1	11
12:15	2	0	2	12	0	12
12:30	0	0	0	16	2	18
12:45	0	1	1	15	0	15
Hour	3	1	4	53	3	56
13:00	1	2	3	10	0	10
13:15	1	0	1	20	0	20
13:30	1	1	2	14	1	15
13:45	2	0	2	11	1	12
Hour	5	3	8	55	2	57
14:00	1	0	1	13	0	13
14:15	2	0	2	9	0	9
14:30	0	0	0	21	0	21
14:45	0	0	0	11	1	12
Hour	3	0	3	54	1	55
15:00	0	1	1	19	0	19
15:15	0	0	0	25	1	26
15:30	0	0	0	14	1	15
15:45	1	0	1	18	0	18
Hour	1	1	2	76	2	78
16:00	0	0	0	21	2	23
16:15	0	0	0	27	0	27
16:30	0	0	0	23	0	23
16:45	0	1	1	25	0	25
Hour	0	1	1	96	2	98
17:00	1	0	1	25	0	25
17:15	0	0	0	39	0	39
17:30	0	0	0	27	0	27
17:45	0	0	0	30	0	30
Hour	1	0	1	121	0	121
18:00	1	0	1	29	0	29
18:15	0	0	0	36	0	36
18:30	0	0	0	21	1	22
18:45	1	0	1	12	0	12
Hour	2	0	2	98	1	99
Total	29	13	42	757	19	776

Site No. 2
Location R287(SE) / L3603 / R287(NW) / L36025
Date 21 February 2018

Time	C to D - R287(NW) to L36025		Veh. Total	D to C - L36025 to R287(NW)		Veh. Total
	LV	HV		LV	HV	
07:00	0	0	0	0	0	0
07:15	0	0	0	0	0	0
07:30	0	0	0	0	0	0
07:45	0	0	0	1	0	1
Hour	0	0	0	1	0	1
08:00	0	0	0	2	0	2
08:15	0	0	0	2	0	2
08:30	0	0	0	0	0	0
08:45	0	0	0	0	0	0
Hour	0	0	0	4	0	4
09:00	1	0	1	1	0	1
09:15	1	0	1	0	0	0
09:30	0	0	0	1	0	1
09:45	0	0	0	1	0	1
Hour	2	0	2	3	0	3
10:00	1	0	1	3	0	3
10:15	1	0	1	1	0	1
10:30	1	0	1	1	0	1
10:45	0	0	0	2	0	2
Hour	3	0	3	7	0	7
11:00	0	0	0	0	0	0
11:15	1	0	1	0	0	0
11:30	1	0	1	0	0	0
11:45	0	0	0	1	0	1
Hour	2	0	2	1	0	1
12:00	0	0	0	0	0	0
12:15	1	0	1	0	0	0
12:30	0	0	0	0	0	0
12:45	1	0	1	1	0	1
Hour	2	0	2	1	0	1
13:00	2	0	2	1	0	1
13:15	2	0	2	2	0	2
13:30	0	0	0	0	0	0
13:45	1	0	1	1	0	1
Hour	5	0	5	4	0	4
14:00	0	0	0	2	0	2
14:15	1	0	1	3	0	3
14:30	1	0	1	1	0	1
14:45	0	0	0	1	0	1
Hour	2	0	2	7	0	7
15:00	0	0	0	0	0	0
15:15	0	0	0	0	0	0
15:30	2	0	2	2	0	2
15:45	1	0	1	1	0	1
Hour	3	0	3	3	0	3
16:00	0	0	0	1	0	1
16:15	1	0	1	0	0	0
16:30	0	0	0	0	0	0
16:45	0	0	0	0	0	0
Hour	1	0	1	1	0	1
17:00	0	0	0	1	0	1
17:15	1	0	1	0	0	0
17:30	2	0	2	1	0	1
17:45	1	0	1	1	0	1
Hour	4	0	4	3	0	3
18:00	1	0	1	1	0	1
18:15	1	0	1	1	0	1
18:30	0	0	0	1	0	1
18:45	2	0	2	1	0	1
Hour	4	0	4	4	0	4
Total	28	0	28	39	0	39

Site No. 2
Location R287(SE) / L3603 / R287(NW) / L36025
Date 21 February 2018

Time	D to B - L36025 to L3603		Veh. Total	D to A - L36025 to R287(SE)		Veh. Total
	LV	HV		LV	HV	
07:00	0	0	0	0	0	0
07:15	0	0	0	0	0	0
07:30	0	0	0	0	0	0
07:45	1	0	1	0	0	0
Hour	1	0	1	0	0	0
08:00	0	0	0	0	0	0
08:15	0	0	0	1	0	1
08:30	0	0	0	0	0	0
08:45	0	0	0	2	0	2
Hour	0	0	0	3	0	3
09:00	1	0	1	2	0	2
09:15	0	0	0	1	0	1
09:30	1	0	1	1	0	1
09:45	0	0	0	2	0	2
Hour	2	0	2	6	0	6
10:00	1	0	1	3	0	3
10:15	1	0	1	1	0	1
10:30	0	0	0	1	0	1
10:45	2	0	2	1	0	1
Hour	4	0	4	6	0	6
11:00	0	0	0	1	0	1
11:15	0	0	0	1	0	1
11:30	1	0	1	2	0	2
11:45	1	0	1	3	0	3
Hour	2	0	2	7	0	7
12:00	0	0	0	3	0	3
12:15	1	0	1	4	0	4
12:30	0	0	0	3	0	3
12:45	0	0	0	5	0	5
Hour	1	0	1	15	0	15
13:00	0	0	0	4	0	4
13:15	1	0	1	0	0	0
13:30	4	0	4	6	0	6
13:45	0	0	0	3	1	4
Hour	5	0	5	13	1	14
14:00	1	0	1	2	0	2
14:15	2	0	2	2	0	2
14:30	0	0	0	1	0	1
14:45	1	0	1	3	0	3
Hour	4	0	4	8	0	8
15:00	0	0	0	2	0	2
15:15	2	0	2	2	0	2
15:30	0	0	0	2	1	3
15:45	1	0	1	7	0	7
Hour	3	0	3	13	1	14
16:00	3	0	3	2	0	2
16:15	1	0	1	5	0	5
16:30	2	0	2	3	0	3
16:45	5	0	5	5	0	5
Hour	11	0	11	15	0	15
17:00	4	0	4	9	0	9
17:15	2	0	2	7	0	7
17:30	2	0	2	2	0	2
17:45	0	0	0	11	0	11
Hour	8	0	8	29	0	29
18:00	0	0	0	11	0	11
18:15	4	0	4	3	0	3
18:30	0	0	0	5	0	5
18:45	0	0	0	4	0	4
Hour	4	0	4	23	0	23
Total	45	0	45	138	2	140

Site No. 2
Location R287(SE) / L3603 / R287(NW) / L36025
Date 21 February 2018

Time	To Arm A - R287(SE)		Veh. Total	From Arm A - R287(SE)		Veh. Total
	LV	HV		LV	HV	
07:00	1	0	1	4	0	4
07:15	3	1	4	8	0	8
07:30	3	1	4	22	0	22
07:45	10	0	10	49	1	50
Hour	17	2	19	83	1	84
08:00	5	0	5	32	1	33
08:15	14	0	14	50	0	50
08:30	12	1	13	42	0	42
08:45	16	0	16	33	0	33
Hour	47	1	48	157	1	158
09:00	22	0	22	31	0	31
09:15	11	0	11	27	1	28
09:30	11	1	12	29	1	30
09:45	19	0	19	29	0	29
Hour	63	1	64	116	2	118
10:00	18	0	18	18	0	18
10:15	13	1	14	19	0	19
10:30	12	0	12	12	1	13
10:45	14	0	14	19	1	20
Hour	57	1	58	68	2	70
11:00	11	1	12	8	0	8
11:15	18	2	20	11	0	11
11:30	13	0	13	11	0	11
11:45	22	0	22	14	2	16
Hour	64	3	67	44	2	46
12:00	16	3	19	22	0	22
12:15	17	0	17	15	0	15
12:30	20	2	22	12	0	12
12:45	20	0	20	10	1	11
Hour	73	5	78	59	1	60
13:00	14	0	14	14	1	15
13:15	21	0	21	19	1	20
13:30	20	1	21	16	0	16
13:45	14	2	16	15	0	15
Hour	69	3	72	64	2	66
14:00	15	0	15	12	0	12
14:15	12	0	12	19	0	19
14:30	23	0	23	13	1	14
14:45	15	1	16	17	0	17
Hour	65	1	66	61	1	62
15:00	21	0	21	17	0	17
15:15	27	1	28	20	2	22
15:30	17	2	19	23	1	24
15:45	27	0	27	13	0	13
Hour	92	3	95	73	3	76
16:00	23	2	25	18	2	20
16:15	33	0	33	16	3	19
16:30	26	0	26	13	0	13
16:45	31	0	31	18	0	18
Hour	113	2	115	65	5	70
17:00	35	0	35	19	0	19
17:15	47	0	47	14	1	15
17:30	29	0	29	20	1	21
17:45	43	0	43	14	0	14
Hour	154	0	154	67	2	69
18:00	41	0	41	11	0	11
18:15	39	0	39	21	0	21
18:30	27	1	28	11	0	11
18:45	18	0	18	9	0	9
Hour	125	1	126	52	0	52
Total	939	23	962	909	22	931

Site No. 2
Location R287(SE) / L3603 / R287(NW) / L36025
Date 21 February 2018

Time	To Arm B - L3603		Veh. Total	From Arm B - L3603		Veh. Total
	LV	HV		LV	HV	
07:00	0	0	0	0	0	0
07:15	0	0	0	1	0	1
07:30	1	0	1	2	0	2
07:45	6	1	7	2	1	3
Hour	7	1	8	5	1	6
08:00	2	1	3	7	0	7
08:15	1	1	2	0	0	0
08:30	3	1	4	3	1	4
08:45	3	0	3	8	0	8
Hour	9	3	12	18	1	19
09:00	1	0	1	3	0	3
09:15	2	1	3	3	0	3
09:30	3	0	3	2	0	2
09:45	2	1	3	5	1	6
Hour	8	2	10	13	1	14
10:00	4	0	4	1	0	1
10:15	3	0	3	1	0	1
10:30	1	1	2	2	0	2
10:45	4	0	4	3	0	3
Hour	12	1	13	7	0	7
11:00	0	0	0	3	0	3
11:15	1	2	3	2	0	2
11:30	4	0	4	3	1	4
11:45	4	0	4	2	0	2
Hour	9	2	11	10	1	11
12:00	4	0	4	3	2	5
12:15	4	0	4	1	0	1
12:30	0	0	0	1	0	1
12:45	0	1	1	2	0	2
Hour	8	1	9	7	2	9
13:00	3	2	5	4	1	5
13:15	2	0	2	2	0	2
13:30	7	1	8	0	1	1
13:45	2	0	2	0	0	0
Hour	14	3	17	6	2	8
14:00	3	0	3	1	1	2
14:15	5	0	5	4	0	4
14:30	0	0	0	1	1	2
14:45	2	0	2	3	0	3
Hour	10	0	10	9	2	11
15:00	0	1	1	2	1	3
15:15	3	0	3	1	0	1
15:30	3	1	4	3	0	3
15:45	4	0	4	3	0	3
Hour	10	2	12	9	1	10
16:00	5	1	6	0	0	0
16:15	3	1	4	1	0	1
16:30	3	0	3	0	0	0
16:45	6	1	7	2	0	2
Hour	17	3	20	3	0	3
17:00	7	0	7	2	0	2
17:15	2	0	2	1	2	3
17:30	3	0	3	4	0	4
17:45	0	0	0	2	0	2
Hour	12	0	12	9	2	11
18:00	1	0	1	1	0	1
18:15	4	0	4	0	0	0
18:30	1	0	1	2	0	2
18:45	1	0	1	2	0	2
Hour	7	0	7	5	0	5
Total	123	18	141	101	13	114

Site No. 2
Location R287(SE) / L3603 / R287(NW) / L36025
Date 21 February 2018

Time	To Arm C - R287(NW)		Veh. Total	From Arm C - R287(NW)		Veh. Total
	LV	HV		LV	HV	
07:00	4	0	4	1	0	1
07:15	9	0	9	3	1	4
07:30	21	0	21	1	1	2
07:45	44	1	45	9	0	9
Hour	78	1	79	14	2	16
08:00	37	1	38	7	1	8
08:15	44	0	44	14	1	15
08:30	35	1	36	12	2	14
08:45	22	0	22	12	0	12
Hour	138	2	140	45	4	49
09:00	25	0	25	20	0	20
09:15	27	0	27	12	0	12
09:30	24	1	25	9	1	10
09:45	26	1	27	14	1	15
Hour	102	2	104	55	2	57
10:00	16	0	16	15	0	15
10:15	18	0	18	14	1	15
10:30	12	1	13	11	1	12
10:45	18	1	19	11	0	11
Hour	64	2	66	51	2	53
11:00	9	0	9	9	1	10
11:15	9	0	9	18	4	22
11:30	9	1	10	14	0	14
11:45	12	2	14	19	0	19
Hour	39	3	42	60	5	65
12:00	17	0	17	11	1	12
12:15	14	0	14	15	0	15
12:30	10	0	10	16	2	18
12:45	11	1	12	16	1	17
Hour	52	1	53	58	4	62
13:00	15	2	17	13	2	15
13:15	19	1	20	23	0	23
13:30	13	1	14	15	2	17
13:45	12	0	12	14	1	15
Hour	59	4	63	65	5	70
14:00	13	1	14	14	0	14
14:15	22	0	22	12	0	12
14:30	13	2	15	22	0	22
14:45	17	0	17	11	1	12
Hour	65	3	68	59	1	60
15:00	15	1	16	19	1	20
15:15	18	2	20	25	1	26
15:30	22	0	22	16	1	17
15:45	12	0	12	20	0	20
Hour	67	3	70	80	3	83
16:00	14	1	15	21	2	23
16:15	13	2	15	28	0	28
16:30	10	0	10	23	0	23
16:45	15	0	15	25	1	26
Hour	52	3	55	97	3	100
17:00	17	0	17	26	0	26
17:15	10	3	13	40	0	40
17:30	20	1	21	29	0	29
17:45	14	0	14	31	0	31
Hour	61	4	65	126	0	126
18:00	12	0	12	31	0	31
18:15	19	0	19	37	0	37
18:30	9	0	9	21	1	22
18:45	10	0	10	15	0	15
Hour	50	0	50	104	1	105
Total	827	28	855	814	32	846

Site No. 2
Location R287(SE) / L3603 / R287(NW) / L36025
Date 21 February 2018

Time	To Arm D - L36025		Veh. Total	From Arm D - L36025		Veh. Total
	LV	HV		LV	HV	
07:00	0	0	0	0	0	0
07:15	0	0	0	0	0	0
07:30	0	0	0	0	0	0
07:45	2	0	2	2	0	2
Hour	2	0	2	2	0	2
08:00	4	0	4	2	0	2
08:15	8	0	8	3	0	3
08:30	7	0	7	0	0	0
08:45	14	0	14	2	0	2
Hour	33	0	33	7	0	7
09:00	10	0	10	4	0	4
09:15	3	0	3	1	0	1
09:30	5	0	5	3	0	3
09:45	4	0	4	3	0	3
Hour	22	0	22	11	0	11
10:00	3	0	3	7	0	7
10:15	3	0	3	3	0	3
10:30	2	0	2	2	0	2
10:45	2	0	2	5	0	5
Hour	10	0	10	17	0	17
11:00	1	0	1	1	0	1
11:15	4	0	4	1	0	1
11:30	5	0	5	3	0	3
11:45	2	0	2	5	0	5
Hour	12	0	12	10	0	10
12:00	2	0	2	3	0	3
12:15	1	0	1	5	0	5
12:30	2	0	2	3	0	3
12:45	3	0	3	6	0	6
Hour	8	0	8	17	0	17
13:00	4	0	4	5	0	5
13:15	5	0	5	3	0	3
13:30	1	0	1	10	0	10
13:45	5	0	5	4	1	5
Hour	15	0	15	22	1	23
14:00	1	0	1	5	0	5
14:15	3	0	3	7	0	7
14:30	2	0	2	2	0	2
14:45	2	0	2	5	0	5
Hour	8	0	8	19	0	19
15:00	4	0	4	2	0	2
15:15	2	0	2	4	0	4
15:30	4	0	4	4	1	5
15:45	2	0	2	9	0	9
Hour	12	0	12	19	1	20
16:00	3	0	3	6	0	6
16:15	2	0	2	6	0	6
16:30	2	0	2	5	0	5
16:45	3	0	3	10	0	10
Hour	10	0	10	27	0	27
17:00	2	0	2	14	0	14
17:15	5	0	5	9	0	9
17:30	6	0	6	5	0	5
17:45	2	0	2	12	0	12
Hour	15	0	15	40	0	40
18:00	1	0	1	12	0	12
18:15	4	0	4	8	0	8
18:30	3	0	3	6	0	6
18:45	2	0	2	5	0	5
Hour	10	0	10	31	0	31
Total	157	0	157	222	2	224



Ireland

9 City Gate,
Lower Bridge Street,
Dublin 8

Tel: 01 633 4725
Fax: 01 633 4562

**PMCE
AUGHNACLIFFE AND AUGHNAMORE
TRAFFIC SURVEYS**

**SURVEY REPORT
FEBRUARY 2018**

PROJECT NO.	8459
CHECKED	P. MURRAY
DATE	06/03/2018
CONTACT	A.CHAMBERS
REVISION	

CONTENTS

Introduction

Junction Turning Counts

Diagrams 8459-01 and 8459-02

Drawings 8459-01 and 8459-02

Appendix A – Vehicle Categories

INTRODUCTION

Nationwide Data Collection (NDC) was instructed by PMCE to undertake junction turning counts in Aghnacliffe, Co. Longford and Aghnamore, Co. Sligo.

General location plans are given in Diagrams 8459-01 and 8459-02.

JUNCTION TURNING COUNTS

Junction turning counts were undertaken at the following sites:

Aghnacliffe, Co. Longford

Site No.	Location.	Day / Date
1	L1039 / L5081 / L5080 / L5066	Tuesday 27 th February 2018
2	L1051 / L5081 / L1048 / L5096	

Aghnamore, Co. Sligo

Site No.	Location.	Day / Date
1	R284(N) / L3603(E) / R284(S) / L3603(W)	Wednesday 21 st February 2018
2	R284(SE) / L3603 / R284(NW) / L36025	

All sites were surveyed using telescopically mounted video cameras from which the information was subsequently extracted. Details of the observed movements are given in Drawings 8459-01 and 8459-02.

The survey was carried out with survey hours of 07:00 to 19:00. All information was collected in 15 minute intervals and has been tabulated with both hourly and period totals.

Vehicles were classified into the following categories:

- Cars and Taxis / Light Goods Vehicles (**LV**),
- Heavy Goods Vehicles / Buses (**HV**).

A detailed description of the vehicles included in each category is provided in Appendix A.

SITE REPORT

Weather	<u>Wednesday 21st February</u> – Overall clear with some sunny spells. <u>Tuesday 27th February</u> - Overall clear with some light snow in the late PM period.
Accidents	None.
Roadworks	None.
Queues	Not required.
Pedestrians	Not required.
General Site Notes.	No additional notes.

APPENDIX A

VEHICLE CATEGORIES

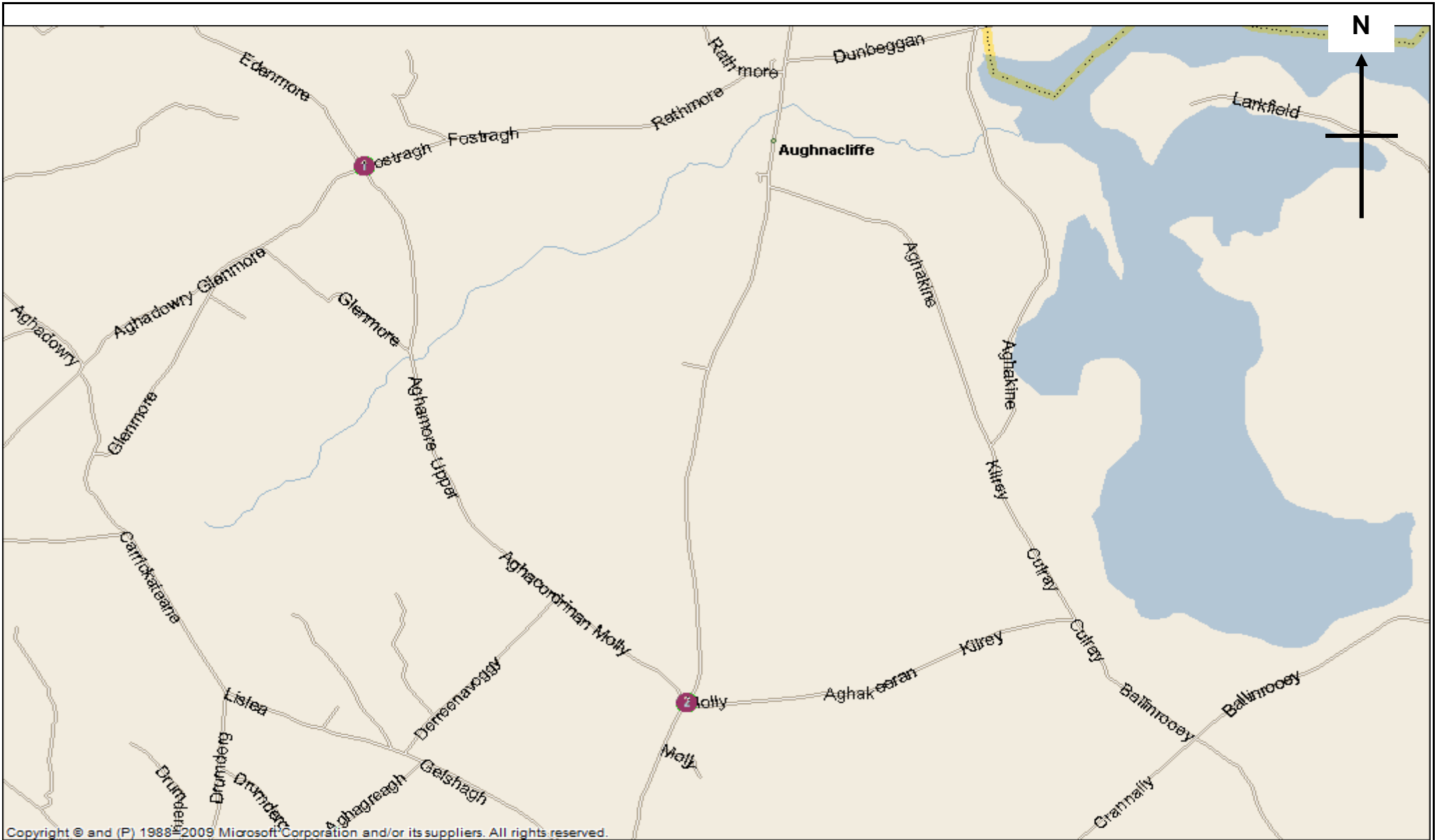

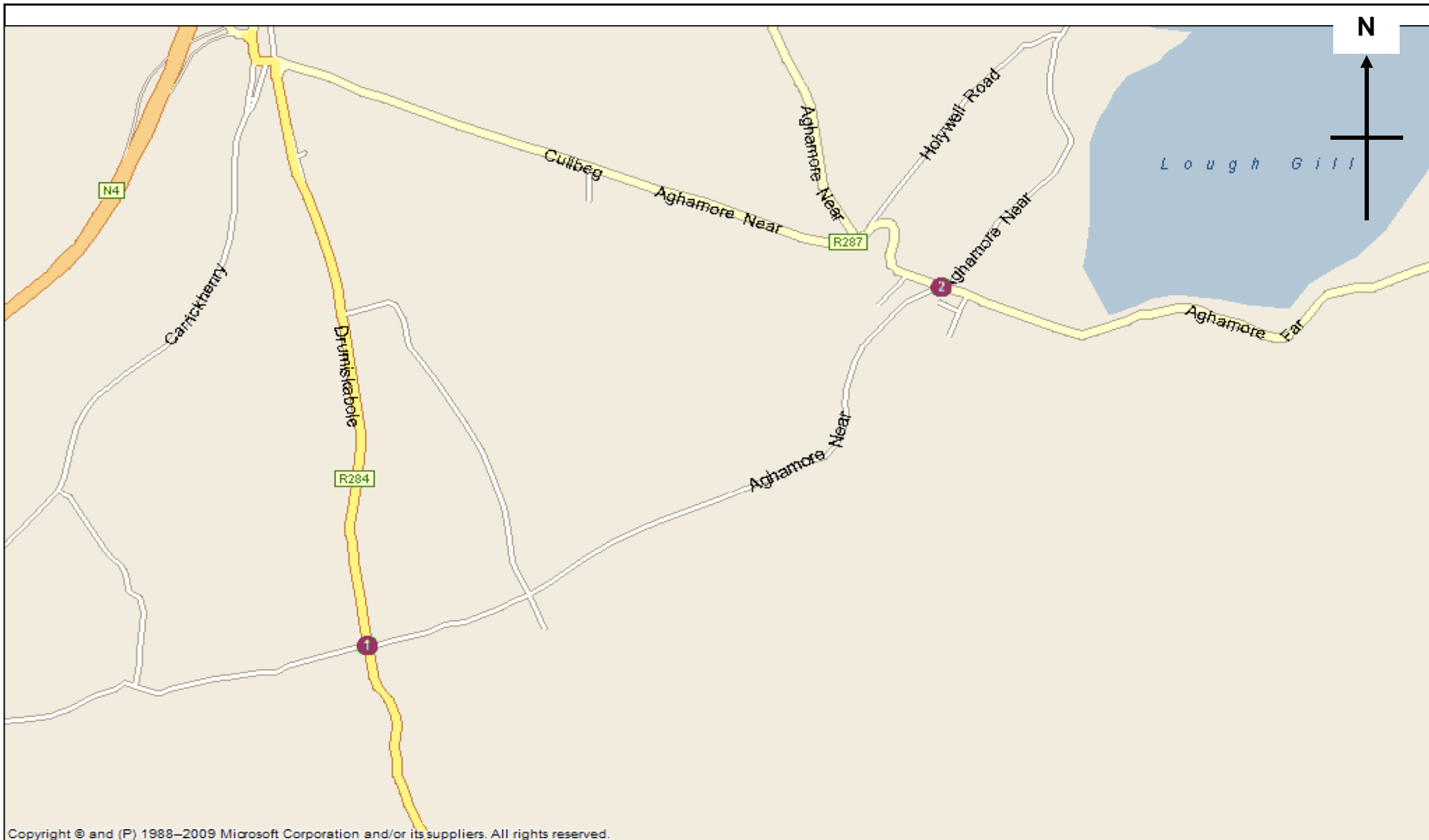

	Sites / Location: 1 & 2 / Longford	Project No: 8459	Diagram No: 8459-01	Drawn By: AC
	Survey Date: Tuesday 27th February 2018	Project Name: AUGHNACLIFFE AND AUGHNAMORE		
	Survey Times: 07:00 to 19:00	Diagram Title: General Location Plan		

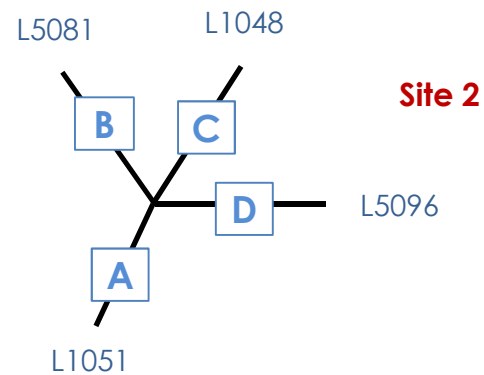
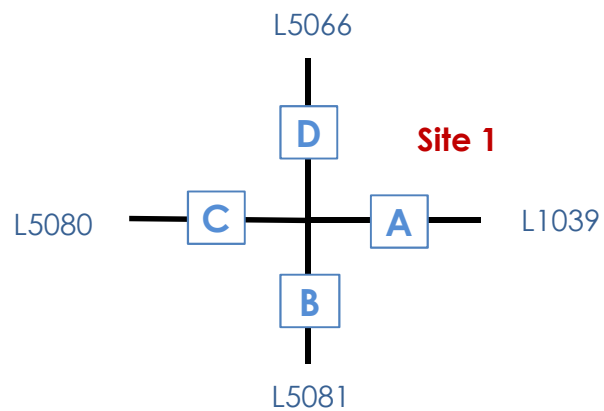
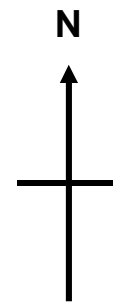

Copyright © and (P) 1988–2009 Microsoft Corporation and/or its suppliers. All rights reserved.

	Sites / Location:	1 & 2 / Sligo	Project No:	8459	Diagram No:	8459-02	Drawn By:	AC
	Survey Date:	Wednesday 21st February 2018	Project Name:		AUGHNACLIFFE AND AUGHNAMORE			
	Survey Times:	07:00 to 19:00	Diagram Title:		General Location Plan			





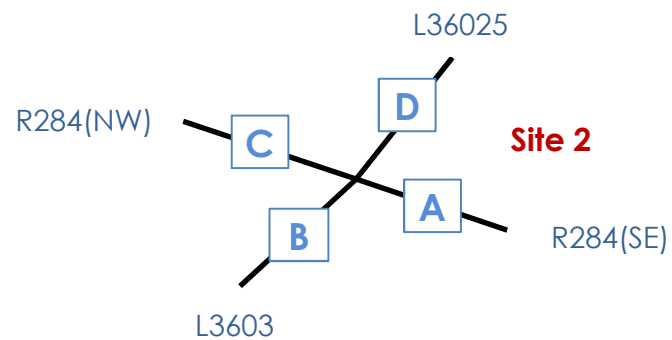
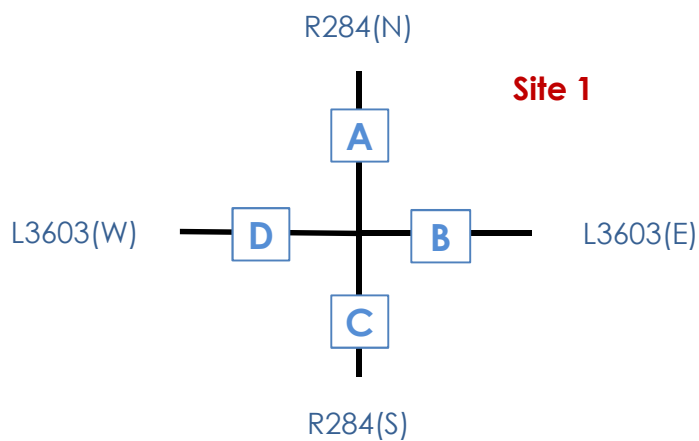
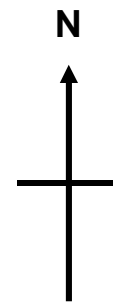













	Sites / Location: 1 & 2 / Longford	Project No: 8459	Drawing No: 8459-01	Drawn By: AC
	Survey Date: Tuesday 27th February 2018	Project Name: AUGHNACLIFFE AND AUGHNAMORE		
	Survey Times: 07:00 to 19:00	Drawing Title: Site Layout and Observed Movements		

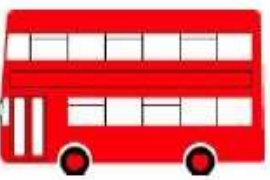

Sites / Location:	1 & 2 / Sligo	Project No:	8459	Drawing No:	8459-02	Drawn By:	AC		
	Survey Date:		Wednesday 21st February 2018		Project Name:		AUGHNACLIFFE AND AUGHNAMORE		
	Survey Times:		07:00 to 19:00				Drawing Title:	Site Layout and Observed Movements	

VEHICLE CATEGORIES

LIGHT VEHICLES (LV)	 SALOON	 ESTATE	
	 PEOPLE CARRIER	 CAR TOWING CARAVAN / TRAILER	
	 VAN	 <3.5 TONNES – single rear tyres	 PICK-UP
HEAVY VEHICLES (HV)	 > 3.5 TONNES – twin rear tyres	 2-AXLES RIGID	
	 2-AXLES RIGID	 3 AXLES-RIGID	
	 4 OR MORE AXLES RIGID	 3-AXLES ARTIC	
	 4 OR MORE AXLES ARTIC	 OTHER GOODS VEHICLE WITH TRAILER	
	 DOUBLE DECK BUS	 SINGLE DECK BUS OR COACH	

VEHICLE CATEGORIES

Definition of Categories

The various components of traffic have different characteristics in terms of operating costs, growth and occupancy. For the purpose of this survey vehicle types are defined as follows:

Cars and Light Goods Vehicles are grouped together as Light Vehicles (**LV**). All other Goods Vehicles, Buses and Coaches are defined as Heavy Vehicles (**HV**).

Cars (CARS)

Including taxis, estate cars, 'people carriers' and other passenger vehicles (for example, minibuses and camper vans) with a gross vehicle weight of less than 3.5 tonnes, normally ones which can accommodate not more than 15 seats. Three-wheeled cars, motor invalid carriages, Land Rovers, Range Rovers and Jeeps and smaller ambulances are included. Cars towing caravans or trailers are counted as one vehicle unless included as a separate class.

Light Goods Vehicles (LGV)

Includes all goods vehicles up to 3.5 tonnes gross vehicle weight (goods vehicles over 3.5 tonnes have sideguards fitted between axles), including those towing a trailer or caravan. This includes all car delivery vans and those of the next larger carrying capacity such as transit vans. Included here are small pickup vans, three-wheeled goods vehicles, milk floats and pedestrian controlled motor vehicles. Most of this group is delivery vans of one type or another.

Other Goods Vehicles (OGV 1)

Includes all rigid vehicles over 3.5 tonnes gross vehicle weight with two or three axles. Includes larger ambulances, tractors (without trailers), road rollers for tarmac pressing, box vans and similar large vans. A two or three axle motor tractive unit without a trailer is also included.

Other Goods Vehicles (OGV 2)

This category includes all rigid vehicles with four or more axles and all articulated vehicles. Also included in this class are OGV1 goods vehicles towing a caravan or trailer.

Buses and Coaches (PSV)

Includes all public service vehicles and works buses with a gross vehicle weight of 3.5 tonnes or more, usually vehicles with more than 16 seats.